

mira *zest*

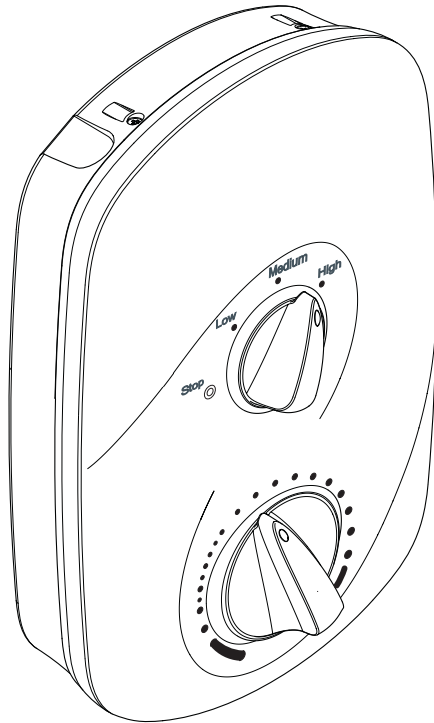

MIRA ZEST

ELECTRIC SHOWER

Installation and User Guide

These instructions are to be left with the user

CONTENTS

Introduction	3
Important Safety Information	4
Pack Contents	6
Specifications	7
Dimensions	7
Wiring Diagram	7
Plumbing	8
Electrical	8
Standards and Approvals	8
Flow Rate Graph	8
Installation Requirements	9
Plumbing	9
Electrical	11
Installation	12
Commissioning	14
Operation	16
Fault Diagnosis	18
Maintenance	22
Cleaning	22
Cleaning the Inlet Filter	22
Relief Valve Assembly - Resetting	23
Spare Parts	24
Spare Parts List	24
Spare Parts Diagram	25
Notes	26
Customer Service	Back Page

INTRODUCTION

Thank you for purchasing a quality Mira Zest Electric Shower. To enjoy the full potential of your new shower, please take time to read this guide thoroughly, and keep it handy for future reference.

Mira Zest electric showers have separate controls for power selection and for temperature/flow adjustment. A unique flow regulator stabilises any temperature changes caused by water pressure fluctuations, which can result from taps being turned on or off or toilets being flushed.

Products covered by this guide:

- Mira Zest 7.5** A 7.5 kW 240 V AC (6.9 kW 230 V AC) heater. Available in a white finish.
- Mira Zest 8.5** A 8.5 kW 240 V AC (7.8 kW 230 V AC) heater. Available in a white finish.

Recommended Usage	
Domestic	✓
Light Commercial	✓
Heavy Commercial	✗
Healthcare	✗

If you experience any difficulty with the installation or operation of your new shower control, then please refer to "**Fault Diagnosis**", before contacting Kohler Mira Limited. Our telephone and fax numbers can be found on the back cover of this guide.

IMPORTANT SAFETY INFORMATION

Warning!

1. Products manufactured by us are safe and risk-free, provided that they are installed, used and maintained in good working order, in accordance with our instructions and recommendations.
2. **THIS APPLIANCE MUST BE EARTHED.**
3. In accordance with 'The Plugs and Sockets etc. (Safety) Regulations' in force at the time of installation, this appliance is intended to be permanently connected to the fixed electrical wiring of the mains system.
4. **DO NOT** twist the individual cable cores of the live and neutral conductors, as this will prevent them from entering the terminal block.
5. Make sure that any pipework that could become frozen is properly insulated.
6. **DO NOT** operate this appliance if it is frozen. Allow the appliance to thaw before using. The shower unit must not be fitted where it may be exposed to freezing conditions.
7. **DO NOT** fit any form of outlet flow control as the outlet acts as a vent for the tank body. Only Mira Showers recommended outlet fittings should be used.
8. If water leaks from the pressure relief valve, maintenance will be required before the appliance can be safely used.
9. There are no user-serviceable components beneath the cover of the appliance. Only a competent tradesperson should remove the cover.
10. If any of the following conditions occur, isolate the electricity and water supplies and refer to **To contact us**, on the back page of this guide.
 - The cover is not correctly fitted and water has entered the appliance case.
 - The case is damaged.
 - The appliance begins to make an odd noise, smell or smoke.
 - The appliance shows signs of a distinct change in performance, indicating a need for maintenance.
 - The appliance is frozen.
11. Isolate the electrical and water supply before removing the cover.
12. Mains connections are exposed when the cover is removed.
13. Refer to the wiring diagram before making any electrical connections.
14. Make sure all electrical connections are tight, to prevent overheating.
15. This product is not suitable for areas with very high humidity (i.e steam rooms). Please consult your installer.

Caution!

1. **Read all of these instructions and retain this guide for later use.**
2. Pass on this guide in the event of change of ownership of the installation site.
3. Follow all warnings, cautions and instructions contained in this guide, and on or inside the appliance.
4. The electrical installation must comply with the “Requirements for Electrical Installations” (commonly referred to as the IEE Wiring Regulations), or any particular regulations and practices, specified by the local electricity supply company in force at the time of installation. The installation should be carried out by an electrician or contractor who is registered, or is a member of, an association such as:
 - National Inspection Council for Electrical Installation and Contracting (NICEIC), throughout the UK.
 - The Electrical Contractors Association (ECA), England and Wales.
 - The Electrical Contractors Association of Scotland (ECAS).
5. This is a high power unit; it is essential to contact your electricity supply company to ensure that the electricity supply is adequate for the purpose.
6. The plumbing installation must comply with the requirements of UK Water Regulations/Bye-laws (Scotland), Building Regulations or any particular regulations and practices, specified by the local water company or water undertakers. The installation should be carried out by a plumber or contractor who is registered, or is a member of, an association such as:
 - Institute of Plumbing (IOP), throughout the UK.
 - National Association of Plumbing, Heating and Mechanical Services Contractors (NAPH & MSC), England and Wales.
 - Scottish and Northern Ireland Plumbing Employers’ Federation (SNIPEF), Scotland and Northern Ireland.
7. This appliance is not thermostatic and can produce scalding temperatures if not operated in accordance with the instructions given in this manual.
8. Anyone who may have difficulty understanding or operating the controls of any shower should be attended whilst showering. Particular consideration should be given to:
 - the young
 - the elderly
 - the infirm
 - the disabled
 - anyone who suffers from a medical condition that can result in temporary incapacity (e.g. epilepsy or blackouts).
 - anyone inexperienced in the correct operation of the controls.
9. When this appliance has reached the end of its serviceable life, it should be disposed of in a safe manner, in accordance with current local authority recycling, or waste disposal policy.

PACK CONTENTS

Tick the appropriate boxes to familiarise yourself with the part names and to confirm that the parts are included.



3 x Wall Plugs

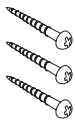

3 x Fixing Screws

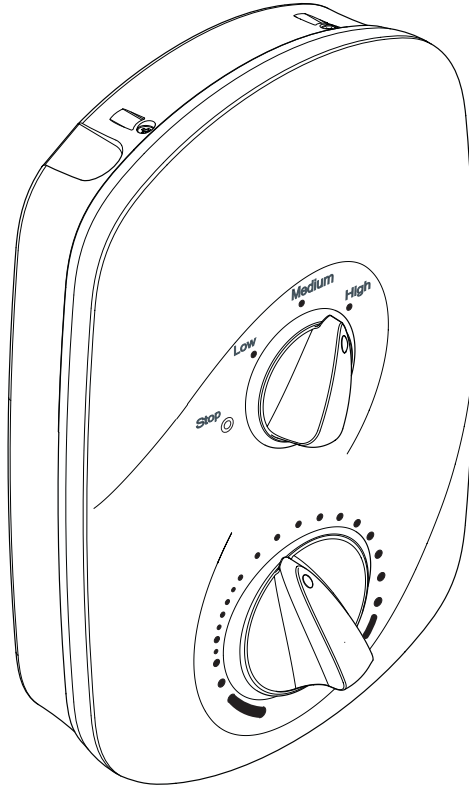

1 x Mira Zest Electric Shower

Documentation

1 x Installation & User Guide

1 x Installation Template

1 x Guarantee Brochure

SPECIFICATIONS

Dimensions

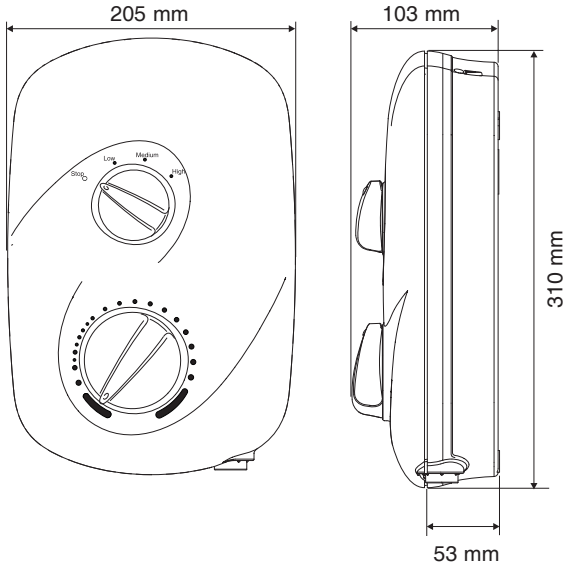

Wiring Diagram

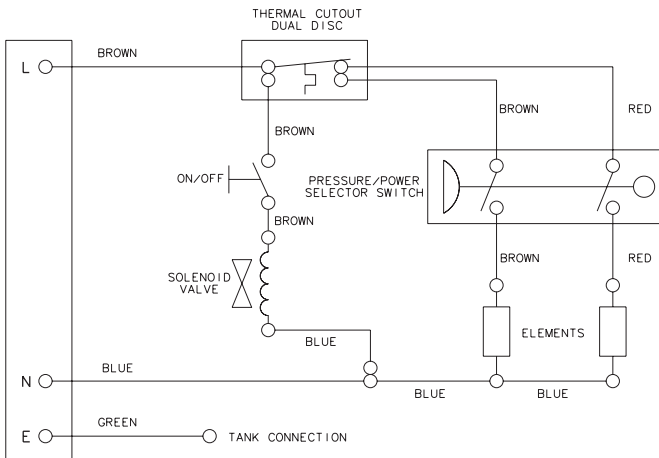

Plumbing

1. Minimum maintained inlet pressure for satisfactory operation: 0.7 bar (70 kPa)
2. Maximum static inlet pressure: 10 bar (1000 kPa)
3. Minimum static pressure to keep the flow valve closed: 0.5 bar (50 kPa)

Electrical

1. The appliance requires a 40 Amp fuse.
2. The terminal block will not accept cable larger than 10 mm².

Standards and Approvals

1. This Mira Zest shower complies with all the relevant directives for CE marking.

Flow Rate Graph

1. These curves are for the specified outputs at 240 V.
2. All appliance heating elements have a manufacturing tolerance. Flow rates may be above or below those shown on the flow rate graph.
3. The left-hand axis shows temperature rise.

Temperature rise = (Showering temperature) - (Supply water temperature)

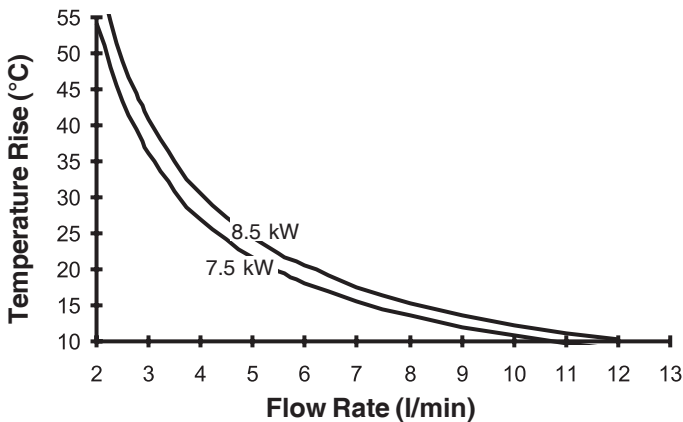

Example: For the Mira Zest 8.5 kW on full power setting with an incoming water supply at 10°C and a showering temperature at 42°C, the temperature rise is 32°C. The flow rate is therefore, 4 l/min.

INSTALLATION REQUIREMENTS

Plumbing

1. The Mira Zest 7.5 kW and 8.5 kW electric showers are designed to operate with a **minimum maintained inlet pressure of 0.7 bar (70 kPa)** up to a **maximum static inlet pressure of 10 bar (1000 kPa)**.
2. The appliance is normally connected to the cold water mains-fed supply. However, the water supply can be taken from a cold water storage cistern, provided there is a minimum maintained inlet head of water of 7 metres (the vertical distance from the base of the cold water storage cistern to the shower fitting handset). To reduce pressure losses and fluctuations, the cistern-fed water supply must be independent from other supply draw-offs, and should avoid long horizontal pipe runs and use swept bends rather than 90° elbows. For further advice please refer to the back cover of this guide for Mira Showers contact telephone and fax numbers.
3. The appliance is suitable for installation within the shower area. It is fitted with a pressure relief device and must be positioned over a water catchment area with the controls at a convenient height for the user. The shower fitting should be positioned so that it discharges down the centre line of the bath, or across the opening of a shower cubicle, and must be directed away from the appliance.
4. The appliance is fitted with an inlet connector assembly that is designed to accept plumbing supplies from the top or bottom. The water supply can be fed with 15 mm pipe or 10 mm microbore pipe, suitably adapted into the inlet connector assembly. If 10 mm microbore is used, then an allowance for increased pressure loss must be made to ensure that the minimum maintained inlet pressure is achieved.
5. **Do not** fit the appliance to the wall and tile up to the case. The appliance must be fitted onto a finished flat and even wall surface. Otherwise, difficulty may be encountered when fitting the cover, and subsequent operation of the unit could be impaired (small pillars moulded on to the back of the case allow air circulation).
6. Use only the inlet connector assembly supplied with the appliance. **Do not** use any other types of fitting.
7. Refrain from applying excessive force when making any connections. Always provide mechanical support when making the plumbing connections.
8. This appliance is not designed to be plumbed directly from the rear. For a rear-entry supply, add an elbow to the supply pipe and connect it as a rising or falling supply.
9. **Do not install the appliance in a position where it may become frozen.** The shower unit must not be fitted where it may be exposed to freezing conditions. The shower unit must not be used if you suspect it may be frozen.

10. We recommend that a non-restrictive (free-flowing) isolating valve is fitted in the cold water supply pipe to allow the complete maintenance of the appliance. **Do not** use a valve with a loose washer plate (jumper) as this can lead to a build up of static pressure.
11. To avoid damage to the case when soldered fittings are used, pre-solder the pipework and fittings before connecting them to the inlet stub.
12. Supply pipework **MUST** be flushed to clear debris before connecting the appliance.
13. The appliance is fitted with a 1/2" BSP male outlet thread, to accept a Mira Zest shower hose.
14. When installed in very hard water areas (above 200 ppm temporary hardness) your installer may advise the installation of a water treatment device, to reduce the effects of limescale formation. Appliance malfunction due to excessive limescale formation is not covered by the manufacturer's guarantee. Your local water company will be able to advise on the hardness of water in your area.

15. A hose retaining ring is supplied to prevent the handset from dropping below the spillover level of the bath or shower, which could lead to contamination from back-siphonage.

The supplied hose retaining ring should meet the majority of user requirements for shower installations with flexible outlet fittings. However, there will be occasions when the hose retaining ring will not provide a suitable solution. In these instances an outlet double checkvalve **must** be fitted. This will increase the required supply pressure typically by 0.1 bar (10 kPa). Double checkvalves, fitted in the inlet supply to the appliance, cause a pressure build-up, which could exceed the maximum static inlet pressure for the appliance.

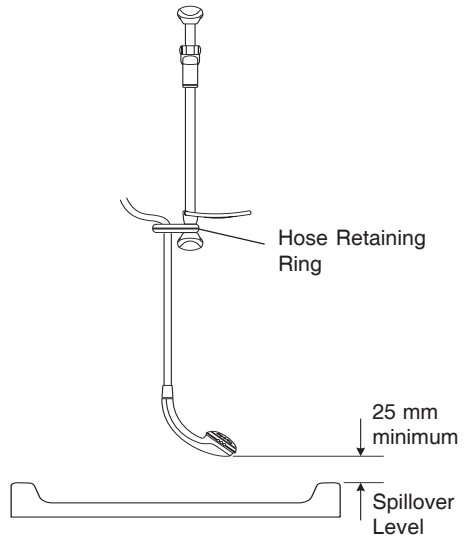

16. Avoid layouts where the shower hose will be sharply kinked. This may reduce the life of the hose.

Electrical

1. In a domestic installation, the rating of the electricity supply company fuse and the consumer unit must be adequate for the additional demand. This is a high-power appliance, and it is essential to contact your electricity supply company to ensure that the supply is adequate for the appliance. Voltage drop due to local heavy demand will reduce the performance of the shower.
2. The appliance **must be earthed** by connecting the supply-cable earth conductor to the earth terminal.

Supplementary bonding: Within the bathroom or shower room, all accessible conductive parts of electrical equipment and extraneous conductive parts that are likely to introduce earth potential, must be electrically bonded to earth using a minimum cable size of 4.0 mm² if the cable is not mechanically protected (2.5 mm² if mechanically protected).

3. The minimum cable size (cross-sectional area) must conform to BS7671
4. To obtain full advantage of the power provided by this unit, use the shortest possible cable route from the consumer unit to the shower.
5. A 30 mA residual current device (RCD) should be fitted. This may be part of the consumer unit or a separate unit.
6. A separate, permanently connected supply must be taken from the consumer unit to the appliance through a double-pole switch, which has a minimum 3 mm contact separation. The switch can be a ceiling mounted pull-cord type within the shower room, or a wall mounted switch in an adjacent room.
7. **DO NOT** twist the individual cable cores of the live and neutral conductors, as this will prevent them from entering the terminal block.
8. **DO NOT** exert strain on the terminal block.
9. **DO NOT** turn-on the electrical supply until the plumbing has been completed.

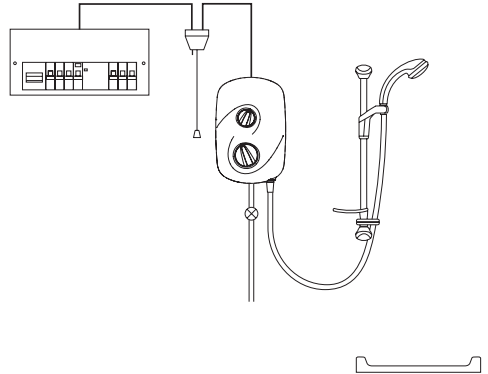

Plumbing and Electrical Schematic

INSTALLATION

Warning! Isolate the electrical and water supplies before installing the shower.

1. Decide on a suitable position for the appliance (minimum distance of 200 mm from the ceiling to allow for cover fit and removal). The position of the appliance and the shower fittings must provide a minimum gap of 25 mm between the spill-over level of the shower tray/bath and the handset. This is to prevent backsiphonage
2. Put the installation template on the wall and mark the positions of the **top two** fixing holes. Ensure that there are sufficient lengths of supply pipe and electrical cable to reach the connection points as shown on the template.
3. Remove the installation template and drill the **top two** fixing holes. Insert the supplied wall plugs.

Caution! Do not drill into cables or pipes in the wall.

4. **Thoroughly flush the supply pipe.**

5. On the shower, turn both knobs to the full anti-clockwise position.

6. Remove the three screws that hold the cover on the shower and remove the cover.

7. Remove the service tunnel from the shower.

8. Determine the direction of the incoming water supply: falling (entering the shower from the top), or rising (entering the shower from the bottom).

Do not use an incoming supply entering the shower directly from the back. Add an elbow to the supply pipe and connect it as a rising or falling supply.

9. Rotate the inlet connector to suit the direction of the incoming water supply.

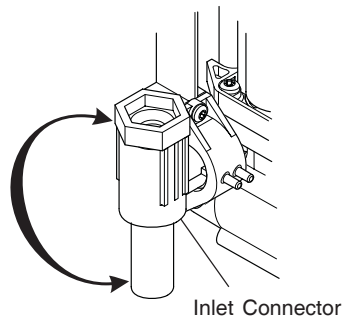
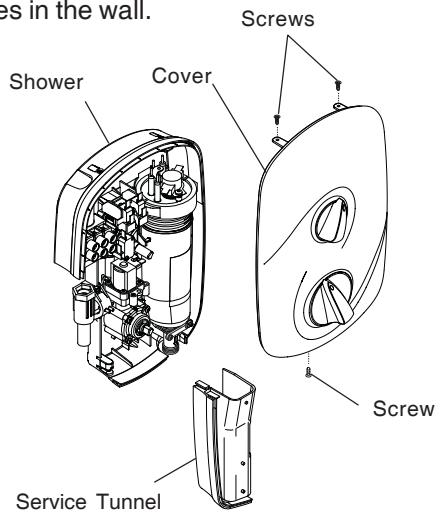

10. The case has thinned sections that can be removed to allow entry of the supply pipe and electrical cables. Remove the top thinned section of the case for a falling supply, or remove the bottom thinned section of the service tunnel for a rising supply.

11. Do not remove any case if the electrical cables enter from the back.

12. Secure the shower to the wall **loosely** through the top two fixing holes, using the supplied screws.

13. Mark the position of the bottom fixing hole.

14. Remove the shower from the wall. Drill the bottom fixing hole and insert the supplied wall plug.

15. Thoroughly flush the mains-fed cold water supply pipe.

Caution! The supply must be clean and free from debris **BEFORE** connecting the appliance.

16. Replace the shower on the wall and secure through the three fixing holes, using the supplied screws.

17. Connect the inlet supply pipe to the inlet connector using a 1/2" BSP nipple with compression nuts and olives (shown) or a push-fit connector.

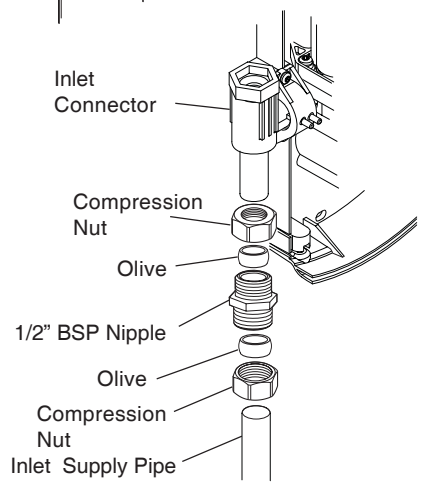
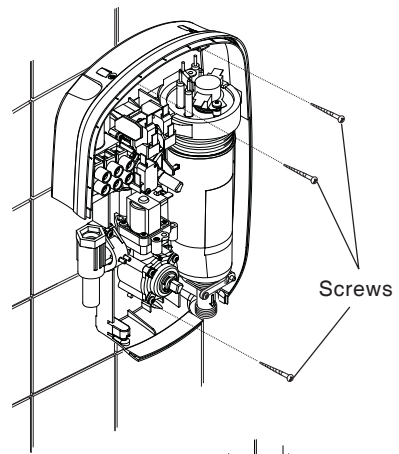
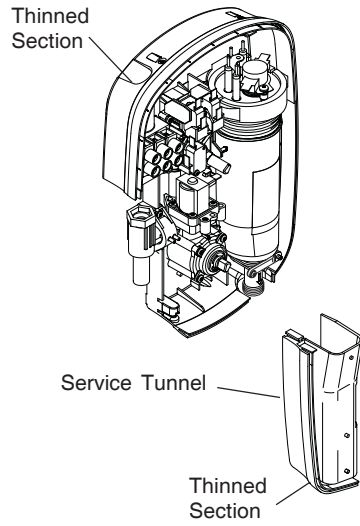

18. Bring the electrical cables into the case.

19. Strip back sufficient of the outer cable insulation to enable routing to terminal block.

20. Fit an earth sleeve to the earth wire.

21. Loosen the screws in the terminal block and insert the bare wires into the clamps.

L (Live) = Brown wire

⊕ E (Earth) = Green sleeved wire

N (Neutral) = Blue wire

Note! Do not twist the cores of the wires or strain the cables to make them reach the terminal block.

22. Connect the conductors firmly into the terminal block. Make sure that the bare cores of each conductor are securely trapped within each conductor clamp.

23. If necessary, fit an earth bonding clamp to the supply pipe and ensure that the bonding complies with the relevant regulations in force at the time of installation.

24. Replace the service tunnel.

25. Replace the cover. If the cover does not fit easily, rotate the knobs slightly so that they fit onto the spindles. Do not force the cover.

26. Tighten the three cover screws.

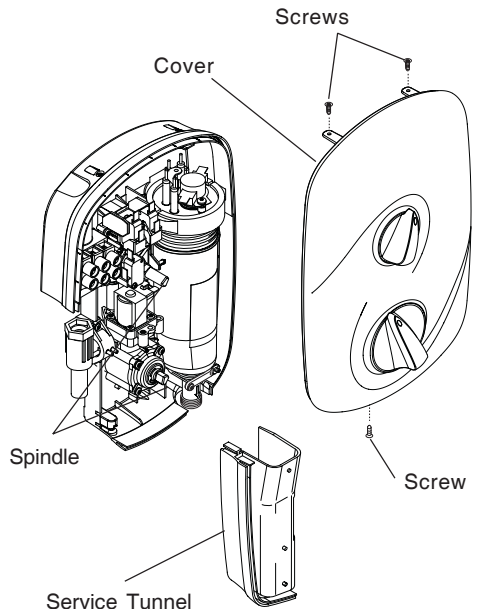
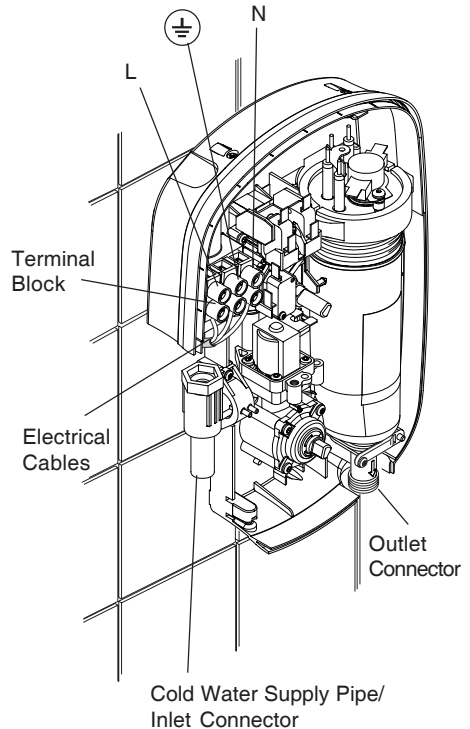

COMMISSIONING

If you are unsure how electric showers work, please read through the **Operation** section before continuing.

1. Make sure that the **TOP** control knob is in the '**STOP**' position and that the electrical supply has been isolated.
2. Turn the **BOTTOM** control knob fully anticlockwise to the full cold position.
3. Turn the water supply fully on at the isolating valve, check that water is not leaking from the bottom of the case.
4. Switch on the electrical supply at the double pole switch.
5. Turn the **TOP** control knob to the '**LOW**' position. Check that water flows freely from the shower within a few seconds. If not, refer to the **Maintenance** section. The water from the handset will be at full force and at a cool temperature.
6. Turn the **BOTTOM** knob slowly clockwise. As the knob is rotated the flow will be reduced and the temperature will remain cool - this shows that the flow regulator assembly is operating correctly. Return the knob anticlockwise to full cold position.
7. Turn the **TOP** knob to the '**MEDIUM**' position. The temperature of the water should rise slightly. Allow a few seconds for the warm water to reach the handset - this shows that the '**MEDIUM**' power setting is operating correctly.
8. Turn the **TOP** knob to the '**HIGH**' position. The temperature of the water will rise further - this shows that the full power setting is operating correctly.
9. Set the shower temperature by rotating the **BOTTOM** knob as necessary. Turn the knob clockwise for hotter water and anticlockwise for cooler water.
Note! When the temperature is changed the flow rate will change.
10. When the required temperature is reached, turn to the **STOP** position to stop the flow. Water may continue to flow from the handset for a few moments during shut-down, as water is purged from the tank. Isolate the power at the double pole switch.
11. A small amount of water may be retained in the shower fitting after the shower control has been turned off. This may drain over a few minutes.
Note! A slight hissing sound may be heard from the appliance during operation. High mains water pressure and high shower temperatures will effect the tone. This is quite normal when the shower is in use.

OPERATION

Advice to Users

Note! Read the **Important Safety Information** section first.

Warning! The spray plate holes must be kept clear. The spray plate should be regularly removed and cleaned in descalent. Lack of regular spray plate cleaning will lead to poor performance and cause early failure of the appliance. See the shower fittings User Guide for more information.

1. Electric showers work by taking in cold water and passing it over the heating elements contained in the tank inside the shower.
2. The showering temperature is adjusted by turning the temperature control knob, which varies the flow of cold water across the elements. The slower the rate of flow, the warmer the water, and vice versa. The holes in the spray plate of the shower handset should always be kept clean to maintain a consistent flow and stable shower temperatures.
3. The appliance is designed to stabilise temperature changes caused by water pressure fluctuations. These fluctuations can be caused by taps being turned on or off, or toilets being flushed. Under such conditions, average shower temperatures will be held within a 6°C range, provided that the minimum required pressure is maintained.
4. Seasonal changes in the temperature of the incoming cold water supply and/or fluctuations in mains electrical voltage will effect the temperature of the water. Adjust the temperature knob as necessary to compensate.
5. The shower requires a minimum maintained/running pressure of 0.7 bar (70 kPa) to operate. At pressures above 0.7 bar (70 kPa), the shower will minimise the temperature fluctuations caused when other draw-off points are used. If the flow rate drops below an acceptable level, the heating element inside the shower will turn off, resulting in a cold shower.
6. If the water temperature reaches an unsafe level, the thermal switch assembly turns off the heating elements. As the water temperature falls the elements will be turned on. The switch will cycle on/off/on if the flow rate is not increased and the temperature of the shower reduced.
7. Check the shower temperature before entering the shower. The previous user may have selected a **different** temperature setting.
8. When the shower is first turned on, or the temperature setting is changed, there will be a slight delay before the water temperature changes.

Operation Instructions

To turn the shower on

1. Switch on the electrical supply at the double pole switch.
2. Turn the power knob to **High**. Wait 15-20 seconds for warm water to reach the handset.

For electrical economy, set the power knob to **Medium**. This setting will provide sufficient power when the supply water temperature is warmer, such as in the summer.

For an unheated shower, set the power knob to **Low**.

To set the shower temperature

1. Set the shower temperature by rotating the temperature knob as necessary. Turn the knob clockwise for hotter water and anticlockwise for cooler water. Wait 10–15 seconds for the adjusted temperature to reach the handset.

Note! It is normal for the flow rate to change when the temperature is changed.

Note! If the water temperature cycles between hot and cold, the temperature is set too high. This is causing the thermal switch to turn off the heating element to reduce the water temperature. Turn the temperature knob anticlockwise to reduce the water temperature.

To turn the shower off

1. Turn the power knob to **Stop**.
Note! A small amount of water may continue to flow from the handset for a few moments.
2. **Switch off** the electrical supply at the double pole switch.

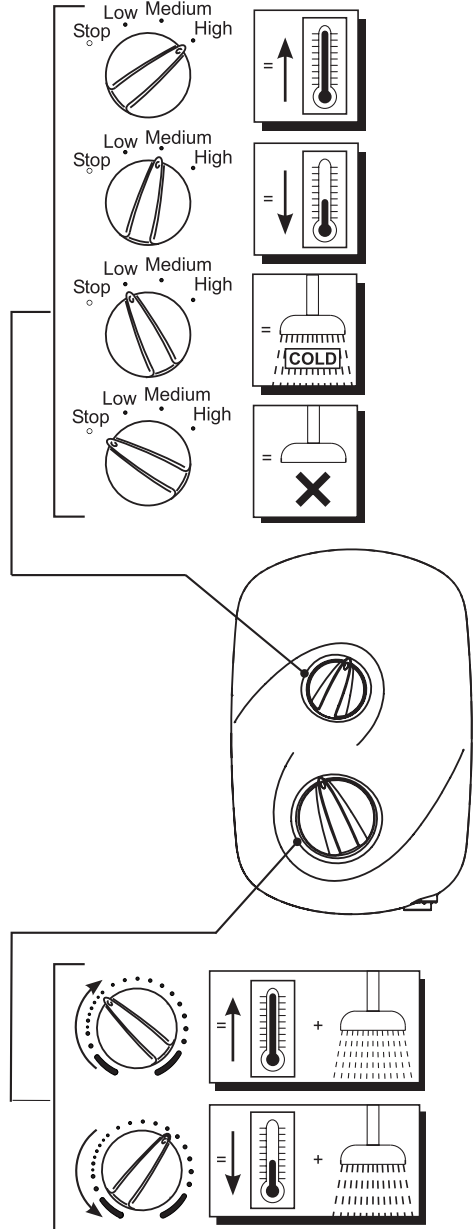

FAULT DIAGNOSIS

The troubleshooting information tabled below gives you details on probable causes and remedies should difficulties be encountered whilst the shower is in operation.

Warning! There are no user serviceable components beneath the cover of the appliance.

ONLY A COMPETENT TRADESPERSON SHOULD REMOVE THE FRONT COVER!

Malfunction	Cause	Remedy
Shower is too hot during the summer.	The incoming water is warmer in the summer, so the shower power setting is too high.	Turn the power knob to Medium and adjust the temperature knob until the desired temperature is reached.
Shower is too hot.	The handset sprayplate is blocked.	Regularly clean the handset sprayplate. Refer to the Maintenance section of the handset manual.
Turning the temperature knob does not affect the water temperature.	The handset sprayplate is blocked.	Remove and clean the handset sprayplate. Refer to the Maintenance section of the handset manual. If the fault persists, contact the shower installer.
The water continues to flow when the double pole switch is turned off.	Broken diaphragm.	Contact your installer to replace the flow valve assembly.
No water or very low flow rate.	<p>The handset sprayplate is blocked.</p> <p>The incoming water supply stop valves, or the appliance isolating valve, is closed.</p> <p>The hose or handset is blocked.</p>	<p>Clean the handset sprayplate. Refer to the Maintenance section of the handset manual. Open the stop/isolating valve completely.</p> <p>Clear the blockage or replace the hose or handset.</p>

Malfunction	Cause	Remedy
	<p>The power is off at the double pole switch.</p> <p>The fuse is blown or the MCB/RCD has been tripped, indicating a possible electrical fault.</p>	<p>Switch on the power at the double pole switch.</p> <p>Renew the fuse or reset the MCB/RCD. If the fault persists, contact the shower installer.</p>
<p>No hot water from shower, with the knobs in any position.</p>	<p>Other water outlets are being used during showering, causing the water pressure to drop below the minimum required.</p> <p>The water pressure is below the minimum required.</p> <p>Failure of pressure switch, micro switch or thermal switch.</p>	<p>Make sure the other water outlets, such as the washing machine or dishwasher, are not in use during showering.</p> <p>Make sure that the incoming water supply stop and the isolating valve are completely open. If the fault persists, contact the shower installer.</p> <p>Contact installer to replace faulty parts.</p>
<p>Temperature cycles between hot and cold.</p>	<p>The temperature is set too high. This is causing the thermal switch to turn off the heating element to reduce the water temperature.</p>	<p>Turn the temperature knob anticlockwise to reduce the water temperature.</p>
<p>ALL OF THE FOLLOWING REMEDIES MUST ONLY BE PERFORMED BY A COMPETENT TRADESPERSON!</p>		
<p>No hot water from shower, with the knobs in any position.</p>	<p>Insufficient water supply pressure.</p> <p>Failure of the pressure switch, microswitch or thermal switch.</p> <p>An internal wiring connection has failed.</p> <p>One of the heater tank elements has failed.</p> <p>Switch assembly diaphragm fault, water dripping from the unit.</p>	<p>Contact the local water authority.</p> <p>Check the continuity of the switches, using a suitable continuity measuring device.</p> <p>Replace the switches as necessary.</p> <p>Check the integrity of the internal wiring.</p> <p>Replace the heater tank.</p> <p>Replace switch assembly.</p>

Malfunction	Cause	Remedy
Shower temperature cycles between hot and cold.	The temperature is set too high. This is causing the thermal switch to turn off the heating element to reduce the water temperature.	Turn the temperature knob anticlockwise to reduce the water temperature. DO NOT TAMPER with the thermal switch.
Turning the temperature knob does not affect the water temperature.	The flow regulator is faulty. The handset sprayplate is blocked.	Replace the flow regulator. Remove and clean the handset sprayplate. Refer to the shower fittings User Guide. If the fault persists, contact Customer Services.
No water or very low flow rate.	<p>The handset sprayplate is blocked.</p> <p>The incoming water supply stop valves, or the appliance isolating valve, is closed.</p> <p>The hose or handset is blocked.</p> <p>Insufficient water supply pressure.</p> <p>The heater tank is excessively scaled.</p> <p>The pilot valve is faulty.</p> <p>The inlet filter is blocked.</p> <p>The power is not turned on at the double pole switch.</p> <p>The fuse is blown or the MCB/RCD has been tripped, indicating a possible electrical fault; for example, heater tank element failure.</p>	<p>Regularly clean the handset sprayplate. Refer to the Maintenance section of the handset manual.</p> <p>Open the stop/isolating valve completely.</p> <p>Clear the blockage or replace the hose or handset.</p> <p>Contact the local water authority.</p> <p>Replace the heater tank.</p> <p>Replace the flow regulator assembly.</p> <p>Clean the inlet filter. See the Maintenance: Cleaning the Inlet Filter section.</p> <p>Switch on the power at the double pole switch.</p> <p>Renew the fuse or reset the MCB/RCD. If the fault persists, contact Customer Services.</p> <p>Replace the heater tank.</p>

Malfunction	Cause	Remedy
<p>Water leaks from the bottom of the case near the outlet, and there is no flow from the handset.</p>	<p>The pressure relief valve in the tank has been triggered, (the shower has a pressure relief valve assembly that works to reduce the damage if the outlet is blocked or the unit is frozen). When the relief valve operates a small rubber ball is ejected.</p>	<p>Resolve the blocked outlet, and replace the tank assembly.</p> <p>Reset the relief valve assembly, refer to Maintenance "Relief Valve Setting" If the fault persists, contact Customer Services.</p>
<p>The water cannot be turned off.</p>	<p>The pilot valve is faulty. Broken diaphragm. The supply pressure is below the minimum requirement.</p>	<p>Replace the flow regulator assembly. Replace the flow regulator assembly. Contact the local water authority.</p> <p>Check the static water pressure. Note that the static pressure may fall below minimum requirement when other appliances are drawing water; for example, the dishwasher or washing machine.</p>

MAINTENANCE

Any maintenance must be carried out by a qualified tradesperson, following the instructions provided. Before replacing any parts, ensure that the underlying cause of the malfunction has been resolved.

Warning! There are no user-serviceable components beneath the cover of the appliance. Only a competent tradesperson should remove the cover.

Cleaning

Many household and industrial cleaners contain abrasives and chemical substances that can damage the finish of your shower. Only clean the shower and fittings with a mild washing-up detergent or soap solution, and then wipe them dry with a soft cloth.

Cleaning the Inlet Filter

Warning! Isolate the electrical and water supplies before removing the cover.

1. Remove the three screws that hold the cover on the shower and remove the cover.
2. Remove the service tunnel from the shower.
3. Use a suitable spanner to remove the filter from the inlet connector assembly. Hold a wrench across the flats of the inlet connector assembly to prevent damage to the connector, whilst removing the strainer.
4. Remove the inlet filter.
5. Clean the inlet filter with a stiff brush. If necessary, use a kettle descaler in accordance with the manufacturer's instructions.
6. Refit the components in reverse order.

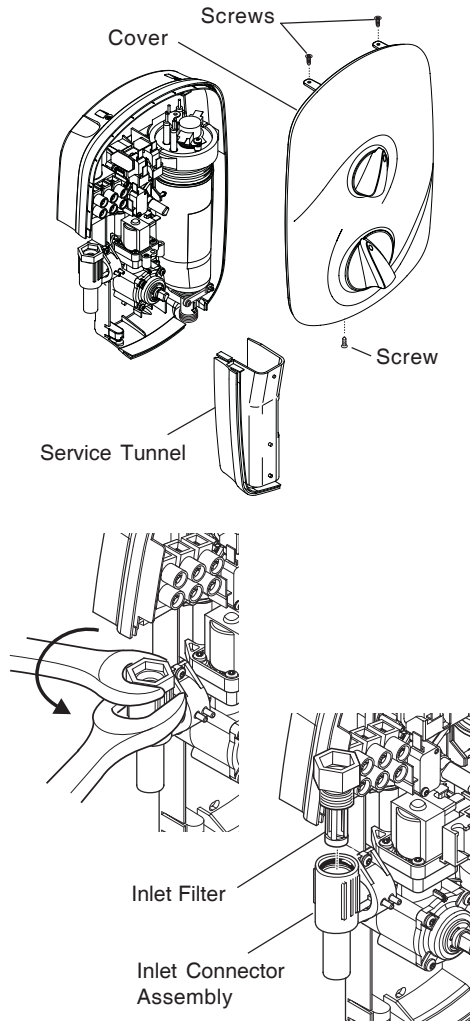

Relief Valve Assembly - Resetting

WARNING! Isolate the electrical and water supplies before removing the cover. Mains electricity connections are exposed when the cover is removed.

1. Remove the three screws that hold the cover, remove the cover.

Note! The rubber ball is ejected to reduce the damage if the outlet is blocked or the appliance is frozen.

2. Remove the five screws that hold the switch assembly, heater tank and, flow regulator assembly.

3. Lift out the switch assembly, heater tank and flow regulator assembly.

4. Using your finger push the ball back into the tank. Do not remove the 'O' seal.

5. Refit the components in reverse order.

6. Replace the cover. If the cover does not fit easily, rotate the knobs slightly so that they fit into the spindles. Do not force the cover.

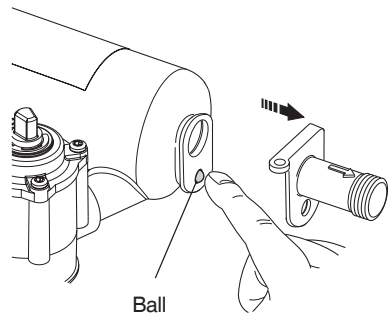
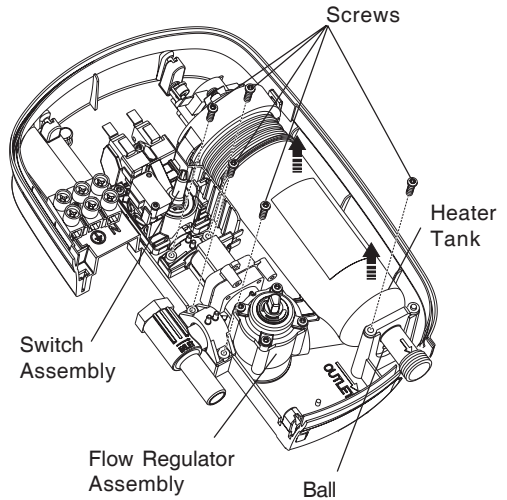

SPARE PARTS

Spare Parts List

406.27	Filter
439.75	Inlet Connector Assembly
439.76	Clamp Bracket Pack (components identified 'A')
439.77	Flow Reg Assembly 7.5/8.5 kW
439.79	Switch Assembly, Rotary
439.81	Cover Assembly, Zest
439.87	Terminal Block Assembly
439.88	Seal Pack (components identified 'B')
439.89	Screw Pack (components identified 'C')
439.90	Thermal Trip Assembly
439.91	Heater Tank Assembly 7.5 kW
439.92	Heater Tank Assembly 8.5 kW
439.95	Service Tunnel
439.99	Tank Outlet and Ball

Spare Parts Diagram

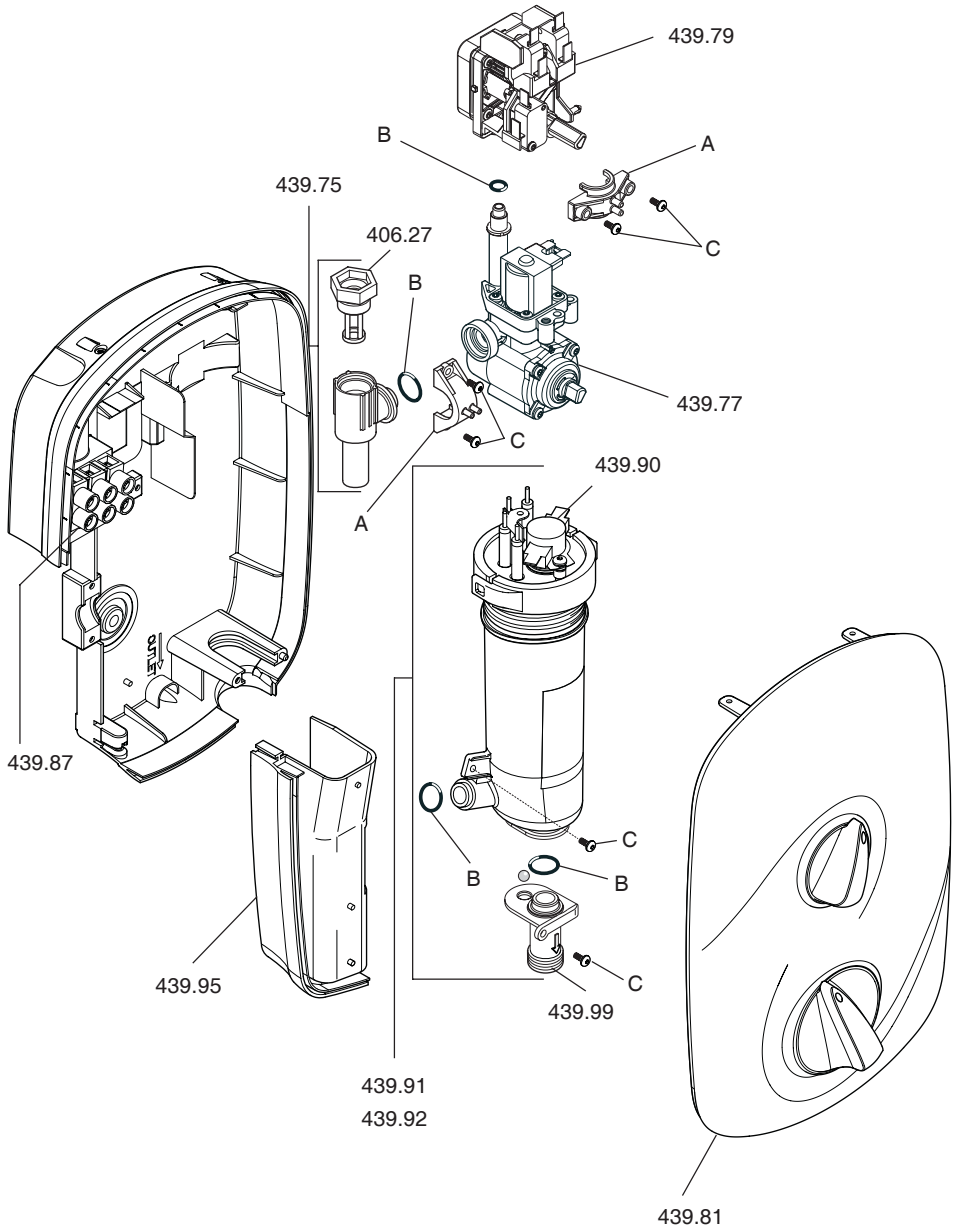

NOTES

NOTES

CUSTOMER SERVICE

Guarantee of Quality

Mira Showers guarantee your product against any defect in materials or workmanship for the period shown in the Guarantee Registration Document included with your shower.

Alternatively, to confirm the applicable guarantee period please contact Customer Services.

To validate the guarantee, please return your completed registration card.

Within the guarantee period we will resolve defects, free of charge, by repairing or replacing parts or modules as we may choose.

To be free of charge, service work must only be undertaken by Mira Showers or our approved agents in Northern Ireland and Republic of Ireland.

Service under this guarantee does not affect the expiry date. The guarantee on any exchanged parts or product ends when the normal product guarantee period expires.

Not covered by this guarantee:

Damage or defects arising from incorrect installation, improper use or lack of maintenance, including build-up of limescale.

Damage or defects if the product is taken apart, repaired or modified by any person not authorised by Mira Showers or our approved agents.

This guarantee is in addition to your statutory and other legal rights.

Before using your shower

Please take the time to read and understand the operating and safety instructions detailed in this manual.

What to do if something goes wrong

If when you first use your shower it doesn't function correctly, first contact your installer to check that installation and commissioning are satisfactory and in accordance with the instructions in this manual. We are on hand to offer you or your installer any advice you may need.

Should this not resolve the difficulty, simply contact our Customer Services who will give every assistance, and if necessary arrange for our service engineer to visit.

If later the performance of your shower declines, consult this manual to see whether simple home maintenance is required. Please call our Customer Services to talk the difficulty through, request service under guarantee if applicable, or take advantage of our comprehensive After-Sales service.

As part of our quality and training programme calls may be recorded or monitored.

Our Customer Services Team is comprehensively trained to provide every assistance you may need: help and advice, spare parts or a service visit.

Spare Parts

We maintain an extensive stock of spares, and aim to have functional parts available for eight years from the date of final manufacture of the product.

Spares can be purchased from approved stockists or merchants (locations on request) or direct from Customer Services.

Spares direct will normally be despatched within two working days. Payment can be made by Visa or MasterCard at the time of ordering. Should payment by cheque be preferred a pro-forma invoice will be sent.

Note! In the interests of safety, spares requiring exposure to mains voltages can only be sent to competent persons.

Service

Our Service Force is available to provide a quality service at a reasonable cost. You will have the assurance of a Mira trained engineer/agent, genuine Mira spares, and a 12 month guarantee on the repair.

Payment should be made directly to the Service Engineer/Agent, using Visa, MasterCard or a cheque supported by a banker's card.

To Contact us

England, Scotland & Wales

Mira Showers Customer Services

Telephone: 0870 241 0888 - Mon to Fri 8:00 am - 5:30 pm
Sat 9:00 am - 4:00 pm

E-mail: technical@mirashowers.com

Fax: 01242 282595

By Post: Cromwell Road, Cheltenham
Gloucestershire, GL52 5EP

Northern Ireland

Wm H Leech & Son Ltd

Telephone: 028 9044 9257 - Mon to Fri 9:00 am - 5:00 pm

E-mail: leech@dnet.co.uk

Fax: 028 9044 9234

Post: Maryland Industrial Estate
Ballygowan Road, Moneyreagh
Co Down, BT23 6BL

Republic of Ireland

Modern Plant Ltd (Dublin)

Telephone: 01 459 1344 - Mon to Fri 9:00 am - 5:00 pm

E-mail: sales@modernplant.ie

Fax: Dublin 01 459 2329

Post: Otter House, Naas Road
Clondalkin, Dublin 22

Modern Plant Ltd (Cork)

Telephone: 021 496 8755 - Mon to Fri 9:00 am - 5:00 pm

E-mail: cork@modernplant.ie

Fax: 021 496 8607

Post: Tramore Road, Cork

Mira Showers
Kohler Mira Ltd
Cromwell Road,
Cheltenham GL52 5EP.

Mira is a registered trade mark of
Kohler Mira Limited.
The company reserves the right to alter
product specifications without notice.
www.mirashowers.com



mira
SHOWERS